

Repair and Installation Help from

# Willcox Inc,

Corvette Parts, Service and Sales

800-588-3883 Orders

For technical assistance email us at

[Willcoxcustomerservice@willcoxcorvette.com](mailto:Willcoxcustomerservice@willcoxcorvette.com)

CHEVROLET—CENTRAL OFFICE

DIVISION OF GENERAL MOTORS CORPORATION  
DETROIT 2, MICHIGAN



## TECHNICAL SERVICE BULLETIN

Technical Service Department



SUBJECT: PARKING BRAKE CABLE CLIP  
RETENTION - 1963 CORVETTE

BULLETIN NO. DR #608

SECTION V

TO: ALL CHEVROLET DEALERS

DATE June 29, 1963

The 1963 Corvette right hand parking brake cable housing is retained to the frame crossmember at the forward end by a U-shaped clip (see 1963 Corvette Shop Manual, page 5-3, fig. 5). During application of the parking brake, movement of the cable housing may allow this U-shaped clip to work loose. Loss of retention will permit the cable to pass through the crossmember resulting in continuous brake drag and subsequent failure.

To prevent this retainer clip from working loose, drill a 7/32" hole and install a 1/4" x 20 self-tapping screw, Part No. 9411890, as illustrated.

### FLAT RATE

0.2 hrs.

Install Parking Brake  
Cable Retaining Screw

A handwritten signature in cursive script, appearing to read "J. R. Runcall".

Director, Technical Service Department

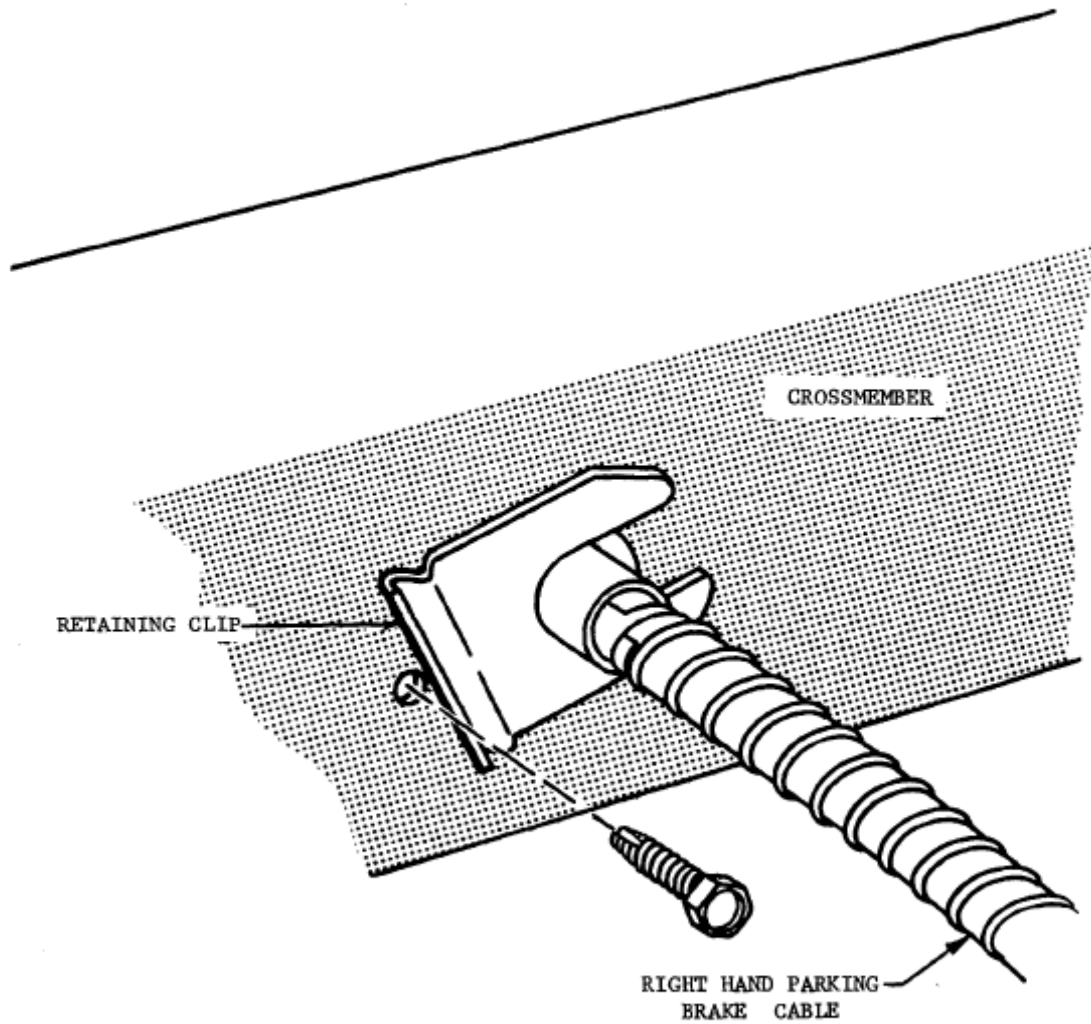

ROTATE CLIP TO POSITION SHOWN  
DRILL 7/32" HOLE AND INSTALL  
1/4 x 20 SCREW TIGHT AGAINST  
CLIP

Property of Willcox Inc. 2008 all rights reserved. Duplication, Distribution or reproduction is strictly prohibited by law.